

12GHT GLOBAL HIGH PERFORMANCE TRASH



Global Pump® High Performance Trash pumps are specifically designed to effectively handle a wide-range of liquids from water to sewage and sludge that can contain solids and other material.

Global Pump High Performance Trash pumps provide a dependable, highly efficient solution. The model 12GHT is capable of achieving maximum flows of 8,500 gpm (1,999 m³/h) and maximum total head of 169' (51.5 m) while handling solids up to 4" (101.6 mm) in diameter.

The standard 12GHT is powered by a water-cooled, 6-cylinder diesel engine. Alternative drives are available, including other diesel engines or electric motor options.

FEATURES

Global Pump's rugged, heavy duty pumps are engineered specifically for portable application

Non-return valve uses only a single moving part to allow full flow with minimal restriction

Standard engine control panel provides preset emergency shutdown protection and allows the addition of automatic level control

Fully guarded coupling

Pump casings are hydrostatically tested to 50 psig (345 kPa) above the peak casing design pressure

Skid-mounted formats with tie downs, lifting bail, and fork pockets

OPTIONS

Available with a variety of priming systems, including Global's Auto Prime® automatic priming system (compressor-fed venturi priming) or a diaphragm priming system

Mechanical seal with glycol (biodegradable optional) quench allows the pump to start and run dry

Global Pump's Environmental Box separates and silences air exhaust and returns liquid to the pump suction.

Fuel cubes for extended run times and/or remote location as required

Sound attenuated enclosure options

Hose racks, accessory containers and other custom features available as required

Wide range of suction and discharge fittings including Global Pump's own "QD" Quick Disconnect fittings and accessories

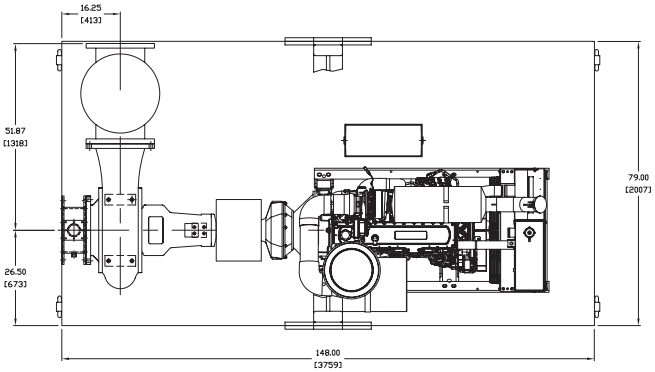
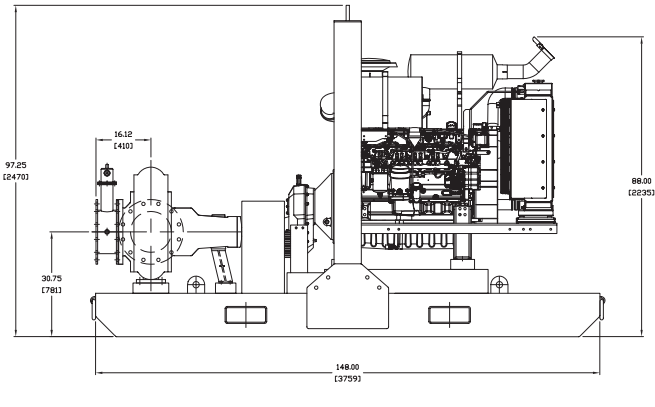

SPECIFICATIONS

Connections	12" (300 mm) ANSI Flanges
Max Pump Speed	1,200 rpm
Max Flow	8,880 gpm (1,999 m ³ /h)
Max Head	169' (51.5 m)
Max Static Priming Lift	28' (8.5 m)
Temperature Limit	160° F (70° C)
Solids Handling Capability	4" (101.6 mm)
Max Casing Pressure	125 psig (862 kPa)
Fuel Cell	325 gallons (1,230 liters)
Dry Weight	10,350 lbs

PUMP MATERIAL

Casing	Cast Iron (CD4MCu is an option)
Impeller	Cast Iron (CD4MCu is an option)
Bearing Housing	Cast Iron
Bearing Lubrication	Grease
Shaft	Stainless Steel
Seal	Silicon Carbide on Silicon Carbide
Chassis/Fuel Cell	Steel
Non-Return Valve	Nitrile Fitted Cast Iron

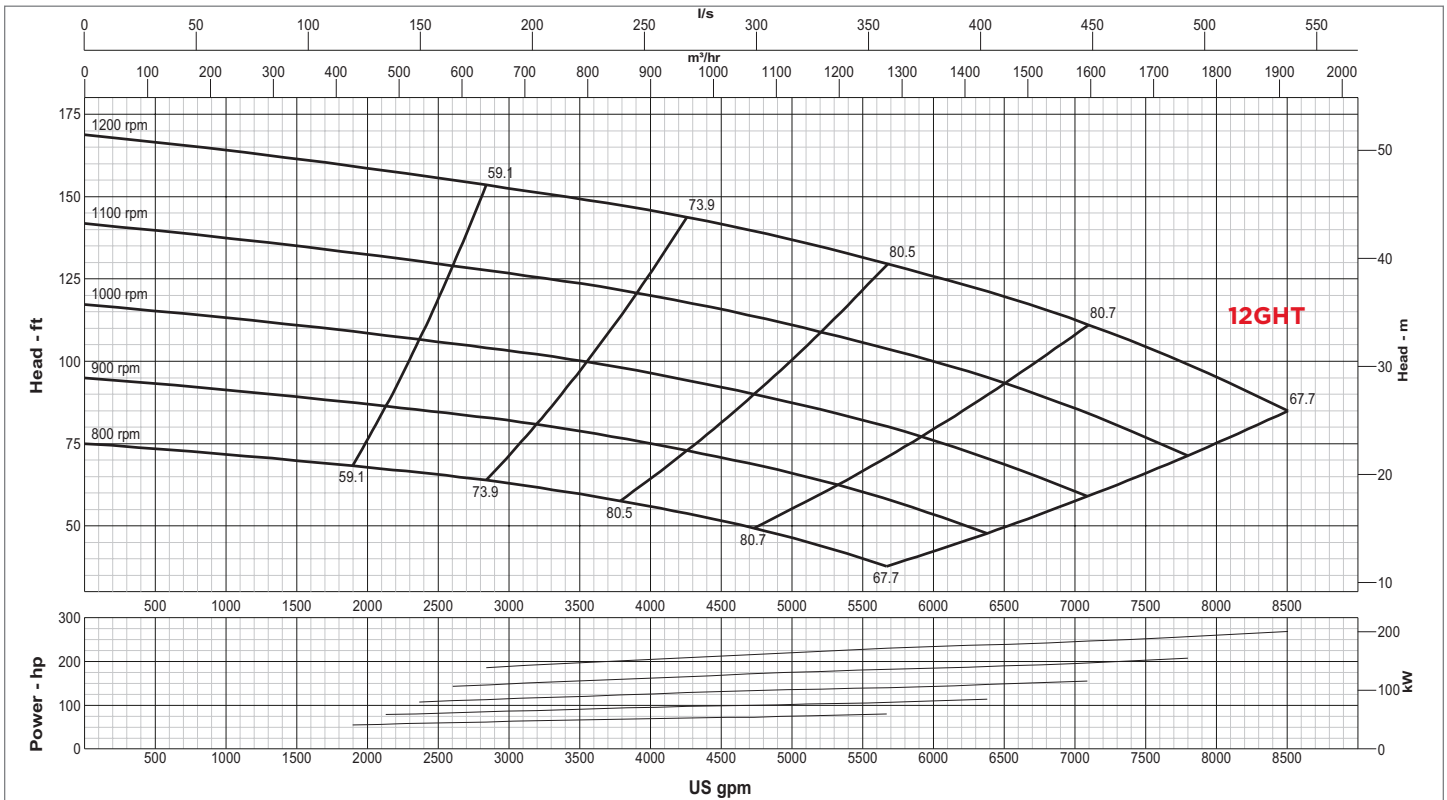

GLOBAL PUMP

10162 East Coldwater Road, Davison, MI 48423

Tel: 810.653.4828 Fax: 810.658.0632

1.866.360.PUMP

www.globalpump.com